

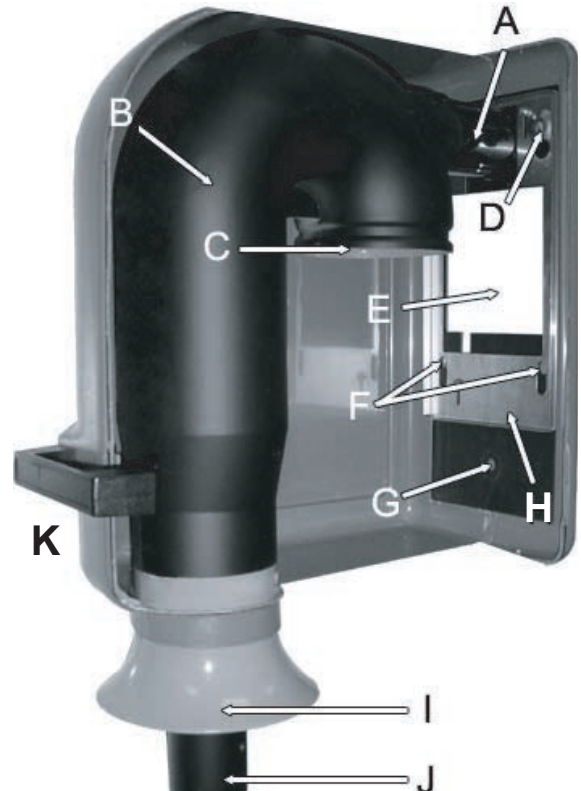

## Preparing Your Commercial Pro for Shipping

### Removing the Housing Unit

1. Remove the wing nuts, lock washers, and flat washers from Part F (Power Pack Bolt Slots).
2. Remove the Philips head machine screw lock washer and flat washer from Part G
3. Slide Part H (Housing Release Lever) up. Place hand on the outside black handle (Part K) and steadily shake the unit back and forth to safely remove housing unit.



### Removing the Power Pack Unit from Base

1. Remove Part L (1/4 inch machine screw) from each side of the Power Pack (shown in bottom figure).
2. Lift the Power Pack from the base bracket
3. Wrap the Power Pack and Regulator in newspaper or bubble wrap and place in the shipping container
4. Be sure to include your Work Order # on the outside of the shipping container to guarantee proper unit identification.

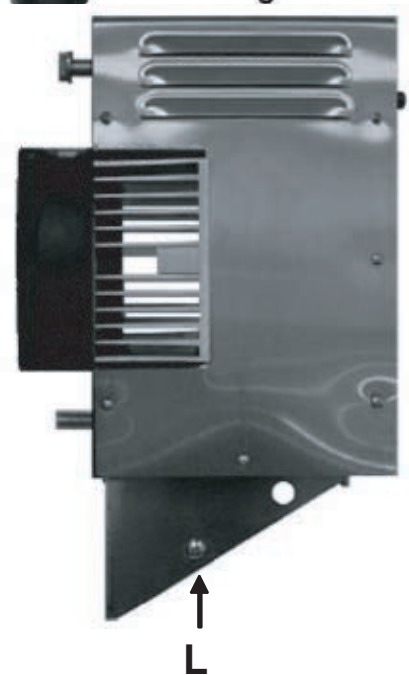

After completing these steps, send your packaged Mosquito Magnet to:  
**Mosquito Control Technology**  
**2384 Durham Dayton Hwy**  
**P.O. Box 858**  
**Durham, CA 95938**

# 1-800-214-7721